

Cube Large

Item # PLG - Q44
22" x 22" x 22"

Final Model #		
Project		
Type	Area	

UPC #:

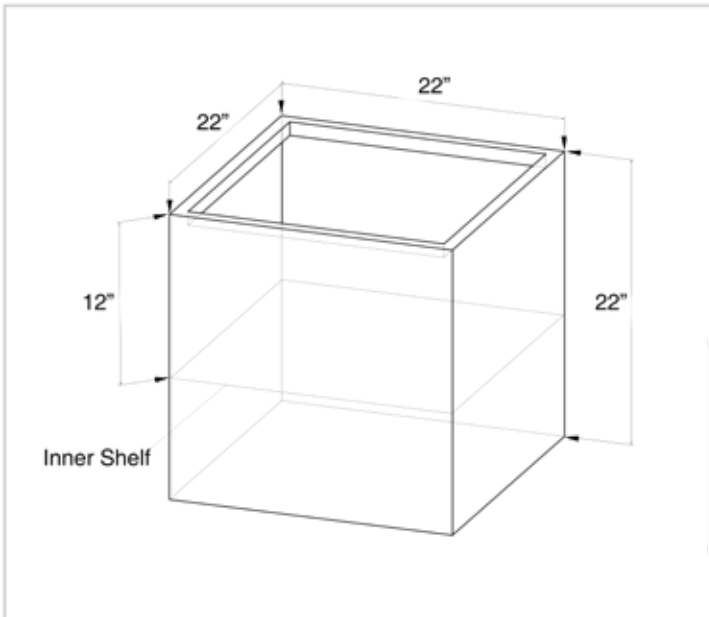

FULL PRODUCT DESCRIPTION

Galvanneal steel offers an ideal surface for painting. Its zinc iron alloyed coating combined with a durable powder coating offers superior performance with excellent longevity. This anti-corrosive steel is designed so oxidation cannot occur. These Planters are perfect for an Entrance, Border, Porch, Poolside, or Balcony. Suitable for indoor or outdoor applications.

KEY BULLET POINTS

- Commercial Grade Planter
- Zinc Coated Galvanneal 18 Gauge Steel Produced in USA
- 1 mm Wall Thickness
- Hand Dressed Full Seam Welds
- Fixed Interior Shelf With 3 Drain Holes
- 3 Drain Hole Base
- 5-Year Structural Warranty, 3-year Finish Warranty

COLOR OPTIONS

Textured

White Onyx Graphite Flax



Vibrant

Orange Lime Citron Teal Cobalt Aubergine



PRODUCT DETAILS

H 22" (56cm)
W 22" (56cm)
D 22" (56cm)
WT 39 lbs (18kg)

